

MONO: Compact with high performance.

In spite of its compact dimensions, the newly-developed, MONO 6 SYSTEM blower continues to impress due to its high air volume of up to 600 l/min. One of its new features is the ability to adjust the air volume, either on the device itself, via the “e-drive” operating unit, or through the external interface. As a result, the blower can be adapted perfectly to suit every application. With its maintenance-free, brushless motor, the blower is ideal for continuous operation.

High pressure blower

MONO⁶ SYSTEM



Technical data

Frequency	Hz	50 / 60
Air flow (20 °C)	l/min	250 – 600
Static pressure	kPa	3.6
Max. ambient temperature	°C	60
Outside diameter air outlet	mm	∅ 38
Weight with 3 m cable	kg	1.0
Conformity mark		CE (ErP n/a)
Protection class II		□

Voltage	V ~	230	120
Power consumption	W	120	120
Order no.		146.702	149.638

Installation dimensions in mm

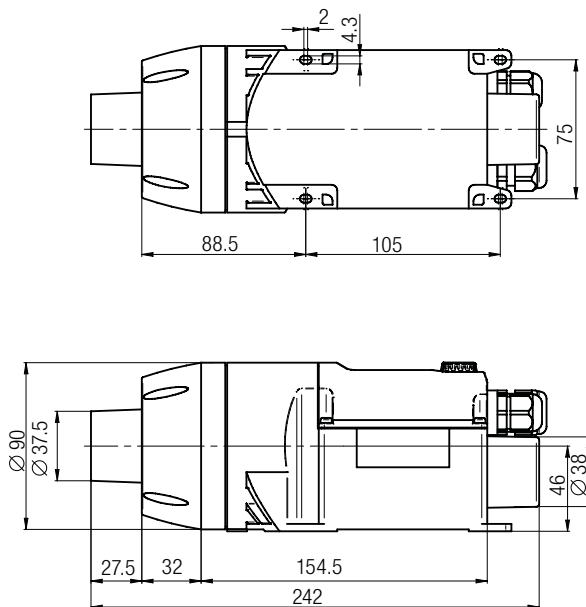

- Adjustable air volume
- Compact and efficient
- “e-drive” operating unit
- Brushless motor
- Tool protection
- System interface
- Mounting tabs

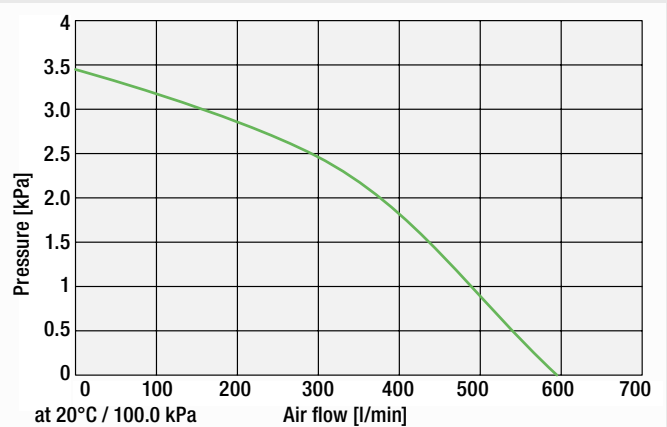

Accessories

