

REXSON 60C60

SINGLE POST RAM (20-30 litres drums)



The REXSON 60C60 pump is specially designed for pumping viscous materials. SAMES KREMLIN equipment can process a wide range of materials including oils, greases, adhesives and sealants.

This equipment has proved itself over the years to be strong and reliable and can process products up to 30.000 centipoises depending on specification.

The system pumps directly from the original material container and is used on 20 to 30 liter pails (interior diameter from 280 to 305mm).

The modular conception allows you to select an extrusion system comprising of a pump, elevator, follower plate, gun and hoses + optional extras including filter, regulator, 4 wheel cart to suit your application.

Equipment compliant with ATEX Directive.

FEATURES

- Modular design
- Air motor design enables precise control
- Direct pumping from 20-30 liters pail
- Shovel pump technology
- Pneumatic driven pump

BENEFITS

- Wide range of options available to suit most applications
- The unique air motor design ensures a constant controlled flow rate with low noise and minimum icing risk
- Clean wipe of the material drum saving materials
- Can be used with a wide range of materials
- Safe for use with solvents and other flammable materials

SPECIFICATIONS

Pressure ratio	60/1
Motor type	3000
Fluid volume per cycle (cc)	60
Free flow rate at 60 cycles (L/mn)	3,6
Fluid Output at 15 Cycles (l/mn)	0,9
Air consumption (m ³ /h) at 30 cycles/mn at 4 bar	30
Maximum air inlet pressure (bar)	6
Maximum fluid pressure (bar)	360
Maximum Fluid Temperature (°C)	60
Seal packings	PTFE + PE
Wetted parts	Carbon steel
Weight (kg) - bare pump	19

FITTINGS

Fitting	Air Inlet	F 3/4" G ⁽¹⁾
	Fluid Inlet	Ø 80
	Fluid Outlet	F 3/4" G

⁽¹⁾ Recommended air supply hose diameter 1/2"

Motor air consumption (m³/min.) (Cubic feet/min).

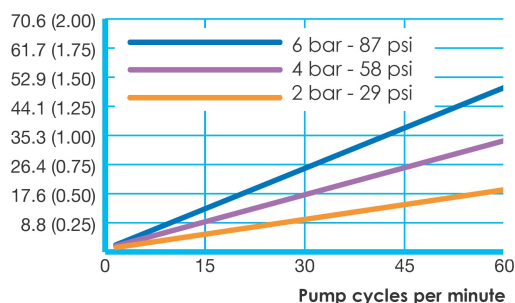

REXSON 60C60 SINGLE POST RAM (20-30 litres drums)

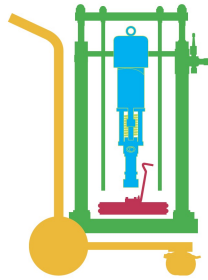

2 ball pumps



COMPLETE PUMP UNIT

Description	Part number
REXSON 60C60 extrusion pump with PTFE/PE seals (☞ I12G IIB T3)	151.040.000



SINGLE POST RAM FOR REXSON 60C60 PUMP

Description	Part number
Single post ram with air control (☞ I12Gc)	151.080.000



FOLLOWER PLATES FOR REXSON 60C60 PUMP

Description	Type	Follower plate Ø (mm)	Follower plate Ø (inches)	Part number
Follower plate - Nitrile	Flat single seal	280 - 285	11 - 11,22	151.100.100
		305	12	151.100.200



CART OPTION

Description	Part number
4 wheel cart (L=1020mm - W=750mm - H=1100mm)	151.098.060



FILTER AND REGULATOR OPTIONS

Description	Part number
Option A: Regulator with fitting and mounting accessories (plate, fittings, hose...)	151.260.985
Option B: Filter with fitting and mounting accessories (plate, fittings, hose...)	151.260.986
Option C: Filter and regulator with fitting and mounting accessories (plate, fittings, hose...)	151.260.987



HOSES AND FITTINGS KITS TO FEED THE GUN

Description	Diameter Fluid hose (mm)	Length (m)	Part number
Ø 3/8" PTFE hose 3/4" JIC fitting, lg 5m with all required fittings	3/8	5	151.260.980
Ø 1/2" PTFE hose 7/8" JIC fitting, lg 5m and PTFE Ø 3/8" whip end 3/4" JIC fitting, lg 2m with all required fittings	1/2 + 3/8	7	151.260.981
Ø 1/2" PTFE hose 7/8" JIC fitting, lg 10m and PTFE Ø 3/8" whip end 3/4" JIC fitting, lg 2m with all required fittings	1/2 + 3/8	12	151.260.982



MANUAL GUN AND ACCESSORIES

Description	Part number
Extrusion gun 500 bar (equipped)	151.110.600
Plastic disposable nozzles (x10)	151.110.290

Expertise in dispensing

General information

REXSON 60C60

SINGLE POST RAM (20-30 litres drums)



3000 AIR MOTOR REPAIR KIT

Description	Part number
Air motor seal kit	146.310.090
2 air motor silencer kit	146.310.091
Distributor kit	146.310.092
Pneumatic kit	146.320.094
Safety valve 6,5 bar	903.080.401

60CC FLUID SECTION REPAIR KIT

Description	Part number
Standard seal kit (PTFE + PE)	144.200.090
Repair kit	144.200.091
Cylinder kit	144.200.092
Optional maintenance kit (graphite-filled PTFE)	144.200.093
Optional maintenance kit (PU + graphite - filled PTFE)	144.200.094



FOLLOWER PLATE REPAIR SEALS

Description	Part number
Ø 280 - 285 mm (11" - 11,2") flat seal	150.048.301
Ø 305 mm (12") flat seal	150.048.302



SINGLE-POST RAM ELEVATOR MAINTENANCE KIT

Description	Part number
Seal kit	151.090.090
Base outlet manometer kit	151.080.094
Manometer outlet back kit	151.080.091
Command button kit	151.080.092
Pushbutton kit	151.080.093
3,8 bar valve kit	903.080.403



FILTER MAINTENANCE

Description	Part number
FKM (Viton) O'ring seal	80.032
Cartridge filter (25 mesh - 710 µ)	601.084
Cartridge filter (50 mesh - 350 µ)	601.092
Cartridge filter (80 mesh - 201 µ)	601.287

REGULATOR MAINTENANCE

Description	Part number
Repair Kit 8 mm	155.750.901
8mm Cartridge	155.750.904



EXTRUSION GUN REPAIR KIT

Description	Part number
Repair kit for 500 bar extrusion gun	151.110.695

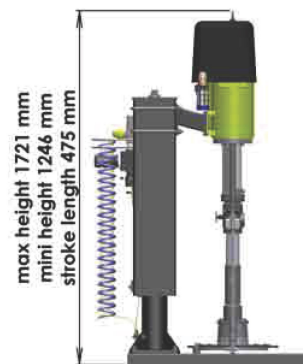
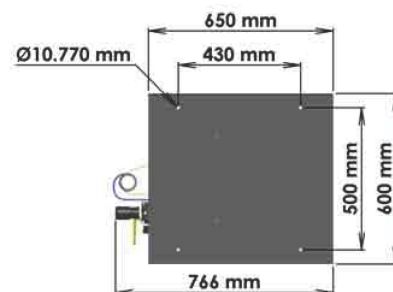

Total weight : 89 kg